



# RT290 RTCH Quick Introduction

William "BIF" Mott  
Director of Customer Solutions  
Independent Rough Terrain Center  
William.mott@IRTC-TX.com  
Cell (210) 240-8872

# What is a RTCH?

- “Rough Terrain Container Handler” **RTCH**



Specifically designed for:

Container Handling in Rough Terrain

Exceptional mobility on-site, ease of transport over the road

High operator situational awareness and secure container movement

Reliable performance and support in remote locations



# What is a RT290 RTCH?

- RT290 RTCH is specifically designed to handle SANDCAN and the oilfield environment



65,000lb Capacity RT290:

Tier IV engine with Arctic kit and Positive Air shutoff  
Operator Camera System with Rear Approach warning  
OmniShift Tophandler for the SANDCAN DTB System

# RTCH stands out from other Equipment

- **Container Handling is done best with Twistlocks and top pick**
  - **Provides load security and speed of handling**
  - **Same activity as occurs with millions of containers at ports**
- **RTCH provides rough terrain performance for final mile logistics**
  - **The RTCH pioneered logistics for International Armies in rough terrain**
  - **Low ground pressure tires for maneuverability (40-80 psi vs 110 for OTR truck)**
  - **4 wheel steering and crab steering for tight operating pads; 23mph travel speed**
  - **RTCH arrives on-site as one piece: it “transforms” into operation in 15 min**
  - **Average operator can move 10-15 containers per hour**
- **1,325 RTCHs are in service today around the world, proudly built in Cibolo, Texas, USA**



# INDEPENDENT RT290 RTCH

## ■ Profile

- Max Lift Ht: 33' 8" (10,300 mm)
- Max Reach: 20' 7" (6,273 mm)
- OAL: 33' 6" (10,210 mm)
- OAW: 12' (3,657 mm)
- HT: 13' 2" operating (4,014 mm)
- HT: 9' 10" transport (2,998 mm)
- Empty WT: 113,500lbs (51,483 kg)
- Cummins 6 cyl, TIER IV, diesel engine
- ZF 4F/2R transmission
- 4 wheel Drive
- 32.5' turn radius
- 4 wheel / 2 wheel / crab steering
- Travel speed: 23/15 mph un/loaded (37 km/h, 24 km/h)
- Gradeability: 27% loaded/unloaded
- Fording Depth: 3' (914 mm)
- Work Tools:
  - Container handler: 65,000lb (29, 483kg) Capacity
  - Single Point Sling rated to 30,000 lbs (13,607 kg)
  - Four Point Sling rated to 40,000 lbs (18,143 kg)





# INDEPENDENT RT290 RTCH

- LogicHaul Options for Oilfield Service
  - 65,000lb (29,483 kg) capacity container handler with OmniShift
  - Camera and Sensor Package
  - Cold weather start assist kit (self contained coolant heater)
  - Oil Drain Kit that follows environmentally friendly practices by reducing fluid spillage while servicing the hydraulic reservoir, transmission and engine.
  - Positive Air Shutoff Kit



# RT290 RTCH Capabilities

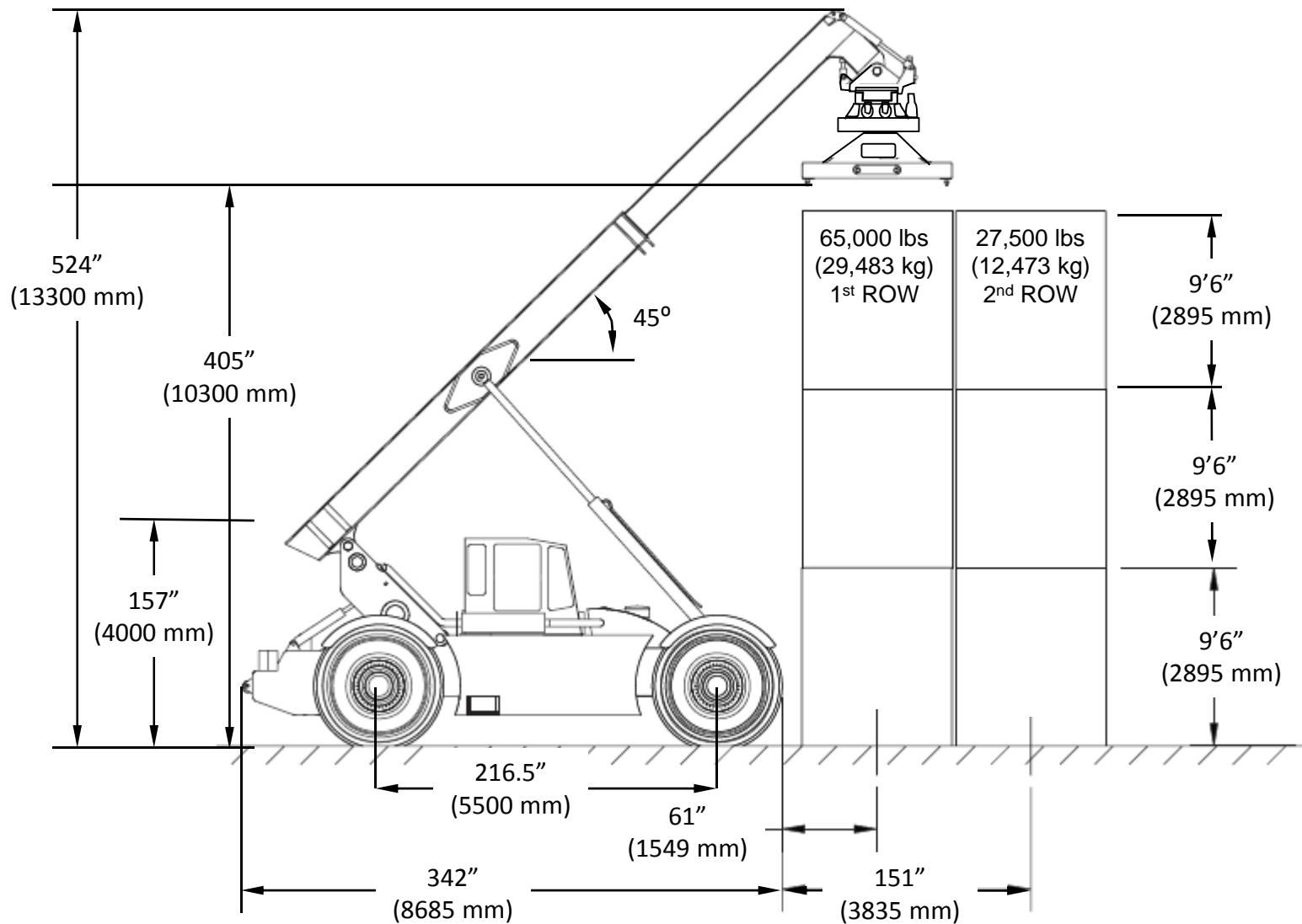

# Summary

- RTCH provides a superior on-site container handling system
- RTCH transports without disassembly via a common 10 axle RGN trailer
- RTCH provides optimum operator visibility and performance
- RTCH is an all weather system, rated from -40F to +120F
- ***What can the RT290 RTCH move for you?***

